

Design of an Absolute Location and Position Measuring System for a Mobile Robot

Dong Hwan Kim*

*Assistant Professor, Department of Mechanical Design, Seoul National University of Technology,
Seoul 139-743, Korea*

Young Chil Park, Hakyoung Chung

*Associate Professor, Department of Control and Instrumentation,
Seoul National University of Technology, Seoul 139-743, Korea*

This paper focuses on a development of a sensor system measuring locations of a vehicle to localize a mobile robot while it tracks on the track (location sensor). Also it focuses on a system configuration identifying the vehicle's orientation and distance from the object while it is stationary at certain station (position sensor). As for the location sensor, it consists of a set of sensors with a combined guiding and counting sensor, and an address-coded sensor to localize the vehicle while moving on the rail. For the position sensor a PSD (Position Sensitive Device) sensor with photo-switches sensor to measure the offset and orientation of the vehicle at each station is introduced. Both sensor systems are integrated with a microprocessor as a data relay to the main computer controlling the vehicle. The location sensor system is developed and its performance for a mobile robot is verified by experiments. The position measuring system is proposed and is robust to the environmental variation. Moreover, the two kinds of sensor systems guarantee a low cost application and high reliability.

Key Words : Location Sensor, Mobile Robot, Magnetic Sensor, Guiding-Counting Sensor, PSD Sensor, Low Cost Position Sensor

1. Introduction

In an automation site, an accurate location and an orientation of a mobile robot while it travels on the rail or stops at the station are to be measured when the mobile robot and other devices are to be cooperated. Two branches of location measuring systems for a mobile robot exist: relative and absolute. The first one is realized by internal sensors such as incremental encoder mounted on the driving wheels or on the steering axis of the vehicle. This method is usually

recognized as a DR (dead reckoning) method by taking encoder reading between landmarks placed at every interval (Schiele and Crowley, 1994; Borenstein, 1994). At each sampling time, the location is measured from the encoder and its value is transferred to the main processor, thus the location is identified. Another relative method is to use an encoder trailer (Fan et. al., 1995; Choi and Kim, 1999). The larger encoder trailer gives larger error due to the limit of encoder's resolution. However, these relative methods degrade a position accuracy when a slip occurs in any wheel of the vehicle. As a result, the errors of each measure are accumulated. Thus, the several error estimation algorithms are reported (Borenstein, 1995; Jetto et. al., 1999; Borenstein and Feng, 1996) for the encoder based measurement. A scheme using a differential encoder and gyroscope is also introduced (Park et. al., 1997). On the

* Corresponding Author,

E-mail : dhkim@plaza1.snut.ac.kr

TEL : +82-2-970-6362; FAX : +82-2-949-2407

Assistant Professor, Department of Mechanical Design,
Seoul National University of Technology, Seoul 139-743, Korea (Manuscript Received August 9, 2000;
Revised July 30, 2001)

other hand, the absolute sensor type is adopted by using a proper set of sensors measuring some parameters of the environment where the vehicle locates. A sonar sensor or ultrasonic sensor (Kuc and Viard, 1990; Figueroa and Mahajan, 1994) is typical of the absolute location measurement for the vehicle. The drawback of the absolute type sensors is their large dependence on the environmental variations. The noise and geometric uncertainty give rise to an error in the location measurement.

In this paper, two categories of the sensor systems (location sensor and position sensor) are defined first. The location sensor is defined here to measure a location while the vehicle travels the guiding line. The sensor system has distinguished feature compared to the conventional way measuring the location which uses landmarks around a track. The details are described in the following sections. The position sensor is defined to measure distance and orientation of the vehicle while it remains stationary at the station.

As for the location sensor, the developed sets of sensors are introduced. These include a combined guiding and counting sensor, a magnetic address decode sensor, and stop sensors. Whenever the vehicle travels along the guiding line its position is updated by counting the marks represented by magnetic bands of N and S pole. Around these marks, two outer tracks used for a guide track are placed up and down the counter band. Meanwhile, the microprocessor updates the information of sensors and transfers those data to the main computer, and it controls the vehicle to travel on the track simultaneously.

On the contrary, the measurement of distance and orientation of the vehicle from the object at a station is implemented via a PSD sensor along with photo-switch sensors. The main novelty of the sensor system is on the capability of measuring accurate position information and of being implemented by a low cost. Furthermore, the sensor is robust to the environmental disturbances. The offset and orientation of the vehicle are calculated by a geometric relationship from the sensor output. The details are shown in the next section.

This paper begins by introducing a newly developed sensor system measuring the location of the vehicle while it travels on the track, and tracking without derailing simultaneously. Section 2 presents a set of sensor system measuring the offset and orientation of the vehicle at the station. In Section 3, a position sensor system with a PSD is introduced and the experimental results of measuring the distance and orientation of the object at the station are provided. The accuracy and reliability for the sensor system are demonstrated in the section. Conclusions are then made in Section 4.

2. Location Measurement System While Moving on the Guiding Rail

As stated before, to localize the vehicle on the track or to identify the vehicle at certain station, a location and position sensor system is required. Two categories of the sensor systems developed here are presented in Sections 2 and 3. The location measurement sensor system is considered first. The main feature of the sensor system is on the capability of measuring and guiding at the same time.

2.1 Description of a set of sensors

Figures 1 and 2 show a test bed for measuring an absolute location of the mobile robot (LABMATE, 1989), and the set of sensors is attached to each side of the vehicle. The computer inside the mobile robot updates the sensor input information through the microprocessor named PIC (PIC, 1999). The computer also controls the vehicle such that it travels on the track without derailing. At each sample, the new position of the vehicle is updated and an appropriate control input is delivered to the motor driver.

At each point of the track, the vehicle's location, offset and heading (orientation) need to be identified. Here, the location represents an absolute position of the center of the vehicle. The offset represents how much the centerline of the vehicle moves from the guiding line. The heading or orientation represents the rotation angle of the vehicle from the base frame coordinates.

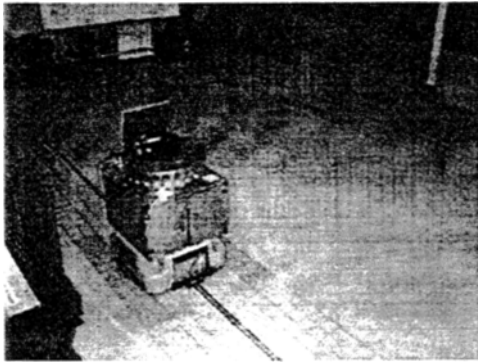

Fig. 1 Test bed for a location measuring sensor in the mobile robot system

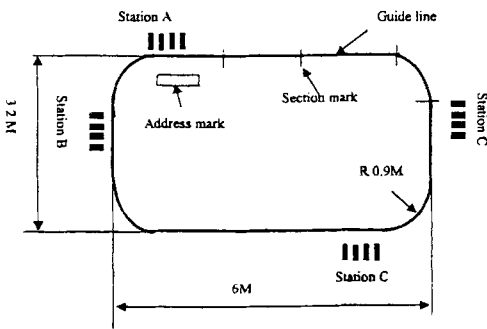

Fig. 2 Dimension of the test bed and placement of the sensors

Figure 3 represents a set of sensors placed on the entire track for the location measuring. Three stop marks near each station are placed on the floor and the first mark is used to reduce the speed of the vehicle when the vehicle detects it. At the second mark, the vehicle stops and starts the calibration of the absolute position in the station. The third mark is used for the opposite direction moving of the vehicle. The address mark sensor (MACOME, 1999) contributes to the absolute location measuring at each station. This sensor reads the 8-digit magnetic-coded mark. When the sensor detects one of these address marks on the track, the absolute location from the location-matched values preset in the computer is estimated and new location information is updated. Next, the combined counting and guiding sensor is described in the following subsection.

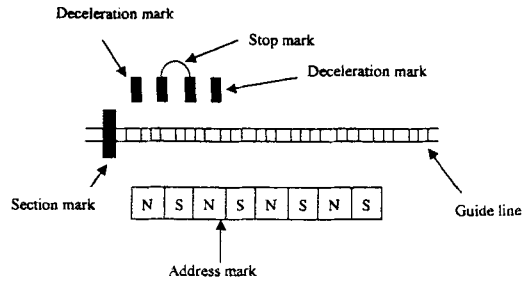

Fig. 3 Locations of a set of sensors

2.2 Combined guiding and counting sensor

The combined guiding and counting sensor plays a role in measuring the location of the vehicle and simultaneously in guiding the vehicle to move along the track. In every specified interval, section marks perpendicular to the track are placed, and they have magnetic codes (either N or S pole) with 8 bits. When the sensor detects a section mark, the counter value is updated by the preset values according to every section. When the vehicle does not detect the section, the computer takes the counter value instead.

In every 90 cm interval, the section marks are placed. The section marks are placed at every interval to identify the vehicle's absolute location even in case the vehicle derails the track and should approach any place in the track.

Figure 4 shows the basic structure of the developed combined guiding and counting sensor. The counting of the combined sensor is described first. The counter marks consist of upper and lower bands. Both bands are placed with a 90-degree phase difference. With this phase, the moving direction of the vehicle is identified. In other words, when the upper band signal falls down, the controller checks whether the signal of the lower part is on (N pole) or off (S pole). If it is on the vehicle travels forward, while if it is off the vehicle travels backward. The direction is determined by just checking the signal of the lower part. Thus, the location and direction of the vehicle are identified according to the counted value and its direction signal. The counter mark is alternatively magnetized with N and S pole and the outer track is also magnetized with N pole.

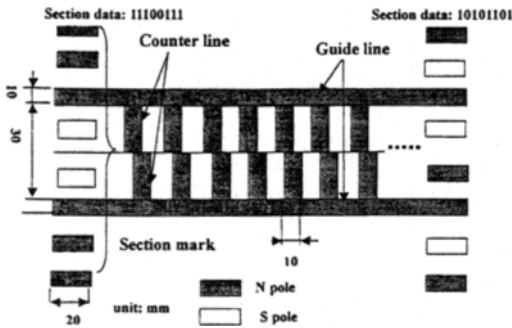

Fig. 4 Combined sensor with counter and guide rail

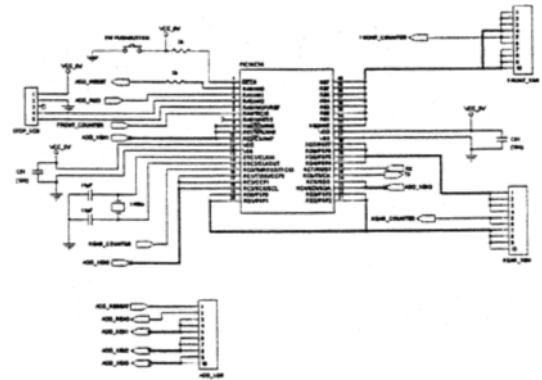

Fig. 7 Electric circuit of set of sensors for the location measurement

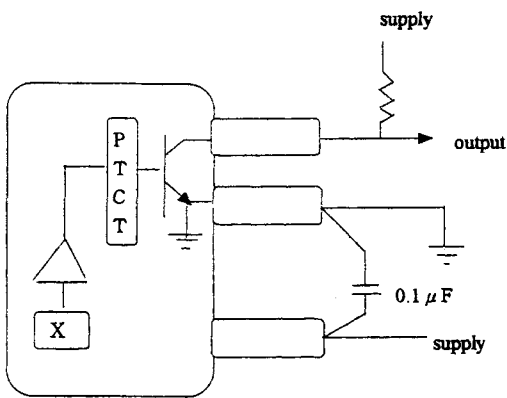

Fig. 5 Circuit of hall-effect sensor

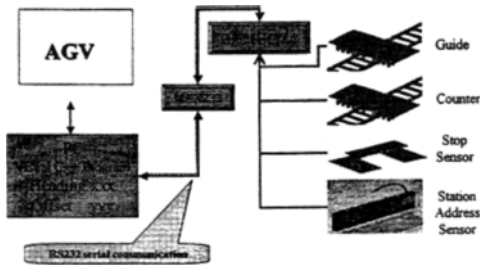

Fig. 6 Sensors integrated system

A hall effect switch (Fig. 5) which is robust to the environment disturbances is used for reading the magnet band (Hall Effect Switch, 1998). The measured value from each sensor is ported to the microprocessor PIC and is transferred to the main computer through an RS232C serial communication (Fig. 6). Figure 7 shows the electric circuit for the measuring system.

The following equations show a mathematical representation regarding to the location value update. Let Sec_i be an i -th section whose value

is determined beforehand by $S_i(k)$ and l be location of the vehicle.

$$d(k) = \begin{cases} S_{i-1}(k) + n & \text{if } Sec_{i-1} < l < Sec_i \\ S_{i-1}(k) & \text{if } l = Sec_{i-1} \\ S_i(k) & \text{if } l = Sec_i \end{cases} \quad (1)$$

where $d(k)$ represents the absolute location data at the k -th location, and n denotes the counted value between sections.

Next, the guiding of the combined sensor is described. Even after the location of the vehicle is identified, other properties are required to identify the vehicle. Those are the heading and offset values of the vehicle. These values are transferred to the computer, and the computer controls the vehicle not to derail by commanding an appropriate offset and heading. In other aspects, these values are required for the vehicle to do cooperative work with other devices. Suppose a loading robot needs accurate information where the mobile robot locates and how it poses to do precise work, then the information should be acknowledged to the loading robot. While the vehicle travels on the track, the exact location of the vehicle needs to be identified. Also, the heading and the offset are required and are computed by the geometric relation of each counting-guiding band. The final values of the offset and heading are determined from the look-up table based on the sensor information (Tables 1 and 2). As the vehicle moves, the obtained offset and heading values are feedback to the vehicle controller to keep the vehicle on the track, then the

error between the reference and the actual offset and heading is compensated by a fuzzy logic algorithm, and finally those are transferred to the motor driver thereafter.

The placement of each guiding sensor is shown in Fig. 8. By a geometric relationship on each guiding sensor the offset and heading values are calculated (Tables 1 and 2). In case the value is not shown in the look-up table, the vehicle is forced to turn inside the track (a clockwise turn

for the clockwise travelling, and vice versa).

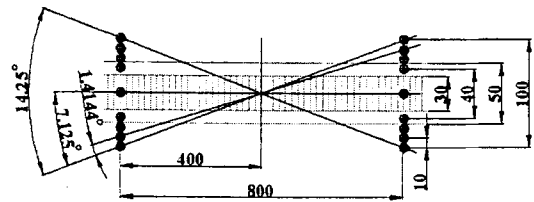

Fig. 8 Sensors location in the mobile robot

Table 1 Calculation Offset values for the mobile robot

		Left sensor values (8 bits data)											
Right sensor (8bits data)		15	143	207	199	239	255	231	247	227	243	241	240
240		-4	-5	-4	-3	-3	-4	-4	-3	-3	-2	-1	0
241		-5	-3	-2.5	-2	-2	-2	-2	-1	-1	-0.5	0	1
243		-4	-2.5	-2	-1.5	-1.5	-1	-1	-0.5	-0.5	0	-0.5	2
227		-3	-2	-1.5	-1	-1	-0.5	-0.5	0	0	0.5	1	3
247		-3	-2	-1.5	-1	-1	-0.5	-0.5	0	0	0.5	1	3
231		-4	-2	-1	-0.5	-0.5	0	0	0.5	0.5	1	2	4
255		-3	-1	-0.5	0	0	0.5	0.5	1	1	1.5	2	3
239		-3	-1	-0.5	0	0	0.5	0.5	1	1	1.5	1.5	2
199		-3	-1	-0.5	0	0	0.5	0.5	1	1	1.5	2	3
207		-2	-0.5	0	0.5	0.5	1	1	1.5	1.5	2	2.5	4
143		-1	0	0.5	1	1	2	2	2	2	2.5	3	5
15		0	1	2	3	3	4	4	3	3	4	5	4

Table 2 Calculated Heading values for the mobile robot

		Left sensor values (8 bits data)											
Right sensor (8bits data)		15	143	207	199	239	255	231	247	227	243	241	240
240		0	-10	-10	-10	-10	-20	-20	-20	-20	-20	-20	-20
241		10	0	-5	-5	-5	-10	-10	-10	-10	-15	-20	-20
243		10	5	0	-5	-5	-5	-5	-10	-10	-10	-15	-20
227		10	5	5	0	0	-5	-5	-5	-5	-10	-10	-20
247		10	5	5	0	0	-5	-5	-5	-5	-10	-10	-20
231		20	10	5	5	5	0	0	-5	-5	-5	-10	-20
255		20	10	5	5	5	0	0	-5	-5	-5	-10	-20
239		20	10	5	5	5	0	0	-5	-5	-5	-10	-20
199		20	10	10	5	5	5	5	0	0	-5	-5	-10
207		20	15	10	10	10	5	5	5	5	0	-5	-10
143		20	20	15	10	10	10	10	5	5	5	0	-10
15		20	20	20	20	20	20	20	10	10	10	10	0

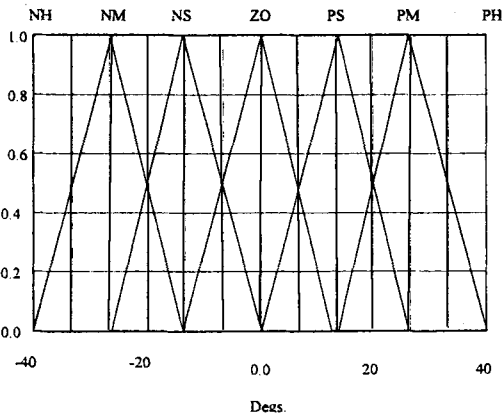

Fig. 9 membership function of heading

The control procedures that the vehicle travels on the track are summarized as follows.

(1) Read the input from the counting-guiding sensor.

$$Sen(k) = (FS(k), RS(k)) \quad (2)$$

where $Sen(k)$ denotes the value of the counting-guiding sensor. $FS(k)$ and $RS(k)$ represent the front sensor and rear value with 8-binary digits, respectively.

(2) Find an appropriate offset and heading from the element in Tables 1 and 2.

$$(Offset, Heading) = T(Sen(k)), \quad (3)$$

where T represents the mapping in Tables 1 and 2.

(3) If found, feedback the error of the offset and heading values to the controller.

$$U(k) = Fuzzy(e_{offset}, e_{heading})$$

$$\text{if}(Offset(Offset, Heading) \in T(Sen(k)), \quad (4)$$

where $U(k)$ represents the control input of the driving motor, and $Fuzzy(\cdot)$ represents the fuzzy algorithm. $e_{offset}, e_{heading}$ represent an error of offset and heading, respectively.

(4) If not found, turn the vehicle inside(outside) direction as to the moving direction.

$$U(k) = \pm \theta \text{ if } (Offset, Heading) \notin T(Sen(k)) \quad (5)$$

where θ is the appropriate angle.

(5) Go to step 1.

Membership functions, and the rule base of the fuzzy control system, are shown in Figs. 9-11 and Table 3. The values of those are adjusted by several experiments.

Table 3 Fuzzy rule

No	If heading error	If offset error	Then Left wheel	Then Right wheel
1	ZO	ZO	PH	PH
2	PH	NS	PH	NH
3	PM	NS	PM	NM
4	PS	NS	PS	NS
5	NS	ZO	NS	PS
6	NH	ZO	NM	PM
7	PH	NH	NH	PH
8	PM	NH	PM	NM
9	PS	NH	PS	NS
10	NS	PS	PS	NS
11	NM	PS	PM	NM
12	NH	PS	PH	NH
13	ZO	PS	PS	NS
14	NH	PH	PH	NH
15	NM	PH	PM	NM
16	NS	PH	PS	NS

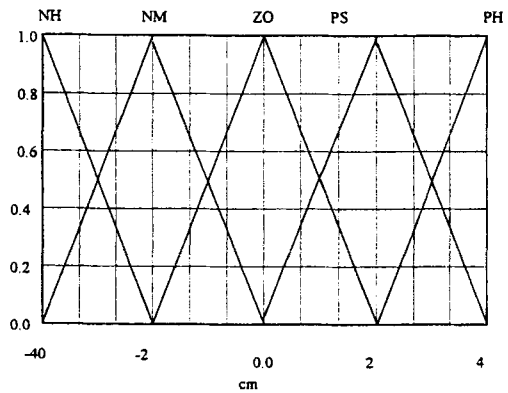

Fig. 10 Membership function of offset

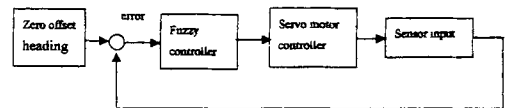
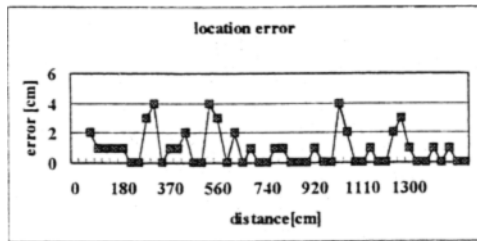

Fig. 11 Structure of offset and heading control system

2.3 Experimental results

Figure 12 shows the experimental results by adopting the developed location measuring system. The experiments are done by moving the



(a)

(a) Location error

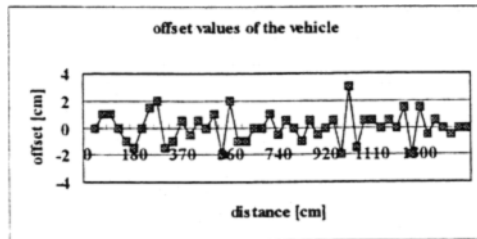

(b)

(b) Offset values

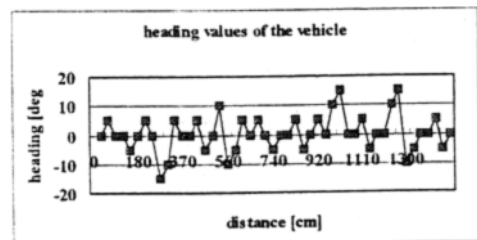

(c)

(c) Heading values

Fig. 12 Experimental results for the combined sensor

vehicle along the track and by obtaining the data from the counter and section marks. The vehicle travels the track one cycle completely and the total distance is about 14.8 m. Viewing the experimental results, the location error in the linear region of the track is small enough to accept. However, at the four corners, there are relatively high location errors than other linear regions due to the cornering. Moreover, the offset and heading values at the corners are different from the true ones. To reduce the errors, there could be several strategies: low speed traveling at corner, different control gain setting, and large radius corner installation. The low speed travelling at corner is better choice compared with other schemes. However, at right after the

Table 4 Control performances with respect to control schemes

Control	Fuzzy	PID	On-Off
Location error [cm]	1.8	2.2	3.5
Heading error average (rms) [deg]	3	5	8
Offset error average (rms) [cm]	1.0	1.5	2.5

corners the section marks are placed and the vehicle updates its location from the section marks, hence the true location values are again updated. Compared with the PID and On-Off control schemes, the fuzzy control scheme shows better performance (Table 4). The updated offset and heading along with the location are monitored in real time by using the visual program and serial communication. Thus, at every instant, all information on the vehicle are enough identified.

3. Absolute Position Measurement in Station

3.1 PSD sensor

In an automation site using a mobile robot, a distance and orientation of the vehicle with respect to the object (called a position sensor) are to be identified when it stops at a certain station. The information of the absolute position and orientation are transferred to other devices such as a handling robot so as to move the end effector of the robot to that position where the vehicle locates. To this end, a position measurement at the station needs to be defined. A sonar sensor or an ultrasonic sensor has been used so far. However, the sensor degrades the accuracy due to a conic field about 15~30 degrees, noise and disturbance by the magnetic materials around the sensor, and insufficient quantity at too much smooth surface on the object. As an alternative, a PSD sensor is introduced. It is a type of photo sensor to measure a distance between the sensor and the object. The position sensor system consists of two infrared sensors and a photo-sensor that react on retro-reflective paper. In this

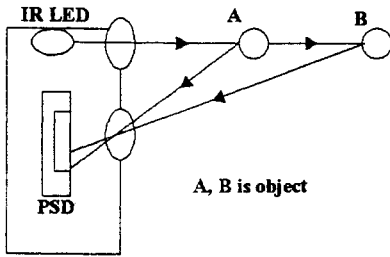

Fig. 13 Principle of PSD sensor

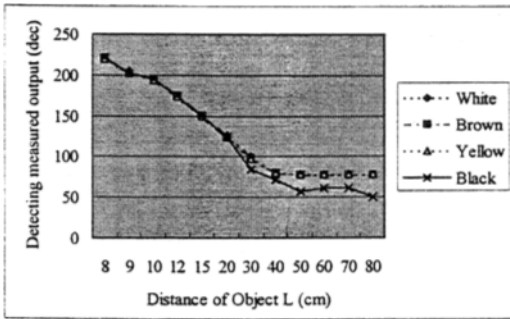

Fig. 14 Measurement data according to the target color variations

study, a DIRRS (Digital Infra-Red Ranging System) sensor manufactured by HWV Ltd. is employed to measure the distance between the object and the vehicle. The orientation is determined by the geometric relationship based on the distance data.

The basic principle of the DIRRS sensor is illustrated in Fig. 13. The infrared light emits from the infrared LED sensor and the PSD sensor receives the reflected light from the object. At the same time, the sensor computes the value of the angle from the mapped signals in the PSD array. Fortunately, the output of the sensor is almost proportional to the distance between the sensor and the reflecting object. The sensor is cheap and easy to handle and is not sensitive to the color and material variations of the reflective object, hence it generates a stable signal under the diverse environment (Figs. 14 and 15). A photo-switch is used to detect the position where the vehicle location is computed through the PSD. The distance data are shown in Fig. 16. Viewing the experimental results, the distances measured by the two PSD have almost same results.

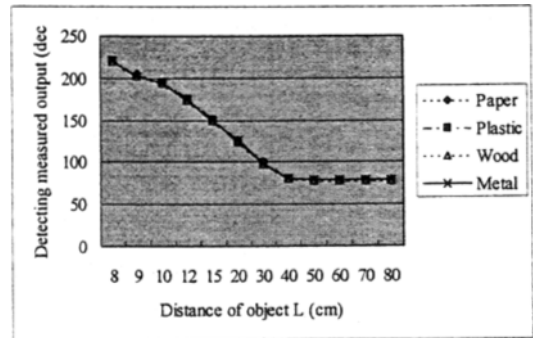

Fig. 15 Measurement data according to the target material variations

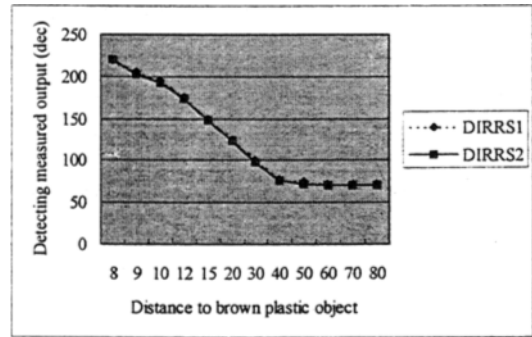

Fig. 16 Measurement data according to the distance variations

For general measurement devices, a landmark with accurate shape and size is needed for a position compensation. However, the landmark used here can be simply designed as long as it is just over 16 mm in width and 20 mm in length. Table 5 represents the position where the signal turns on while the distance between the sensor and the object becomes far off. When we set zero while the photo-sensor output is on for 8 cm distance, the on-position of the sensor while the photo sensor moves parallel to the wall is measured. Ideally, the detection position should be constant under the distance variations. However, the detection position varies as the measuring distance changes due to the cone-type light beam emission (Fig. 17). Thus, detection error arises. The error should be compensated somehow.

Table 5 Experimental results for the photo switch according to distance variations

		(unit: cm)										
Distance		8	9	10	12	15	20	30	40	50	60	70
Detection position		0	0	0	0.05	0.1	0.3	0.45	0.8	1.1	1.5	1.6

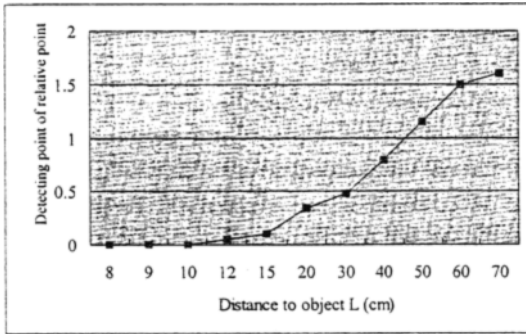

Fig. 17 Error according to the distance variations

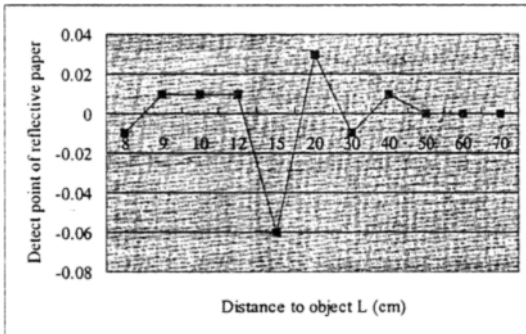

Fig. 18 Position error by the compensated function

By a least square method the error of the detection position is written as

$$e(x_s) = -1.1 \times 10^{-9} x_s^7 + 2.89 \times 10^{-6} x_s^6 - 3.07 \times 10^{-5} x_s^5 + 1.7 \times 10^{-3} x_s^4 - 5.28 \times 10^{-2} x_s^3 + 0.9 x_s^2 - 7.53 x_s + 23.67 \quad (6)$$

where

$$e(x_s) = y(x_s) - y_c(x_s) \quad (7)$$

Here, x_s is the distance, $e(x_s)$ is the error value by the compensated function, $y(x_s)$ is the position where the photo-switch is on, and $y_c(x_s)$ is the compensated function. As a result of the compensation, the position errors are shown in Fig. 18, hence it shows a reasonable outcome.

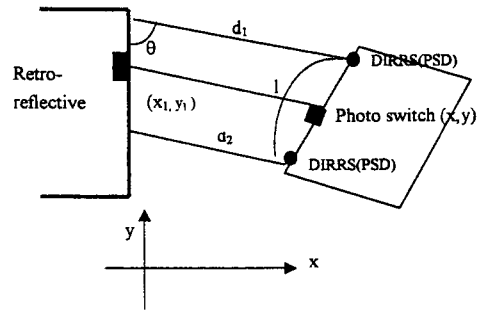

Fig. 19 Measured distances between PSD and retro-reflective object

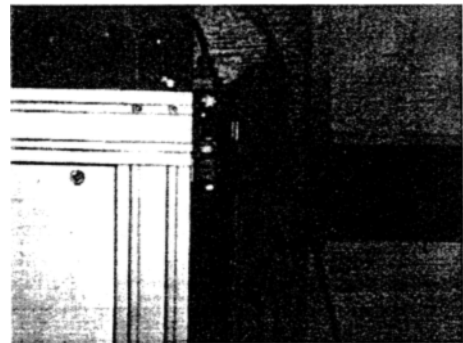

Fig. 20 Installation of the PSD sensor and photo switch

3.2 Calculation of the position and orientation

The distance and orientation of the object are calculated by Eq. (8) from the geometric properties shown in Fig. 19

$$\begin{aligned} \theta &= \tan^{-1} \left(\frac{l}{|d_1 - d_2|} \right) \\ x &= x_1 + \frac{d_1 + d_2}{2} \sin \theta \\ y &= y_1 + \frac{d_1 + d_2}{2} \cos \theta \end{aligned} \quad (8)$$

where d_1 and d_2 are the distances measured by the PSD, and x_1 and x_2 are the location of the vehicle. l is the distance between two PSD sensors. As seen from Eq. (8), the PSD sensor just reads the distance between the object and sensor, and then the true distance and orientation of the vehicle are computed. Figure 20 shows the sensor installation for measuring an absolute position and orientation of the object. In the upper and lower side,

Table 6 Heading angles according to sensor distances

Sensor distance	20 cm					
Actual angle	1	2	4	6	8	10
Measured angle	1.82	3.17	4.58	6.90	8.76	10.67
Sensor distance	40 cm					
Actual angle	1	2	4	6	8	10
Measured angle	1.24	2.17	4.12	6.13	7.94	10.03
Sensor distance	60 cm					
Actual angle	1	2	4	6	8	10
Measured angle	1.23	2.14	4.01	6.05	8.10	10.50

two PSD sensors are placed and the photo sensor is placed between those sensors. About 10 cm away from the vehicle a retro-reflective object is placed.

3.3 Appropriate installation distance of the PSD

The two DIRRS sensors need to be separated enough to have a feasible performance. However, the limitation on the workspace of the mobile robot and the installation area in the vehicle prohibits long enough space for the sensors. Therefore, the distance needs to be determined so as to obtain an exact direction angle computed by Eq. (8). By the experimental results, the accuracy increases as long as the distance is far away, but it does not increase any more over 40 cm in distance (Table 6). However, the infrared sensor does not guarantee the accuracy any more over 25 cm distance because of its low accuracy characteristics. Finally, 40 cm in distance is set by considering both an easy sensor installation and its performance of accuracy.

4. Conclusion

New absolute location measuring sensor systems for a mobile robot are presented. Those are for measuring while a mobile robot is both tracking on the rail and is stationing at station. As for the location sensor system: measuring the location on the rail, the proposed set of sensors consists of a combined guiding and counting,

magnetic address coded sensor, and stop sensors. The sensor system guarantees its accuracy at least 10 mm while tracking, and the measuring accuracy depends on the precise fabrication of the magnetic bands. The sensor system is integrated with a microprocessor and main computer. The main feature for the location sensor is on the counting and guiding at the same time. The combined guiding and counting sensor guarantees the precise location of the vehicle, and simultaneously the estimated offset and heading of the vehicle are commanded to the computer in order to keep the vehicle on the track without derailling. Placing the section sensors in appropriate intervals, the counting error is compensated and true data are updated. The 8-bit section mark extends to a long track with placing a large number of sections.

As for the position sensor system: measuring distance and orientation from the object at the station, a PSD sensor with photo switches is introduced. The sensor system is cost effective and accurate to be adapted with a satisfactory level. Furthermore, it is much free from the environment disturbances than any other sensors. The distance and orientation are calculated by the geometric relation on each sensor. The PSD with photo switches needs to be appropriately separated by considering the sensor accuracy and its feasible installation space.

Acknowledgement

This work was supported by the research fund of Seoul National University of Technology.

References

- Borenstein, J., 1994, "The CLAPPER: A Dual-Drive Mobile Robot with Internal Correction of Dead-Reckoning Errors," *Proceedings of IEEE International Conferences on Robotics and Automation*, pp. 3085~3090.
- Borenstein, J., 1995, "Internal Correction of Deadreckoning Errors with a Dual-Drive Compliant Linkage Mobile Robot," *Journal of Robotic Systems*, Vol. 12, No. 4, pp. 257~273.
- Choi, J. S., and Kim, B. K., 1999, "Position

Estimation of Wheeled Mobile Robot Using Encoder Trailer," *Journal of Control, Automation and System Engineering*, Vol. 5, No. 3, pp. 306~313.

Borenstein, J., and Feng, L., 1996, "Measurement and Correction of Systematic Odometry Errors in Mobile Robots," *IEEE Transactions on Robotics and Automations*, Vol. 12, pp. 869~880.

Fan, Z., Borenstein, J., Wehe, D., and Koren, Y., 1995, "Experimental Evaluation of an Encoder Trailer for Dead-Reckoning in Tracked Mobile Robots," *Proceedings of 10th IEEE International Symposium on Intelligent Control*, pp. 571~576.

Figuroa, F., and Mahajan, A., 1994, "A Robust Navigation System for Autonomous Vehicles Using Ultrasonics," *Control Engineering Practice*, Vol. 2, No. 1, pp. 49~59.

Hall Effect Switch Manual, 1998, Allegro microsystems inc.

Jetto, L., Longhi, S., and Vitali, D., 1999,

"Localization of a Wheeled Mobile Robot by Sensor Data Fusion Based on a Fuzzy Logic Adapted Kalman Filter," *Control Engineering Practice*, Vol. 7, No. 6, pp. 763~771.

Kuc, R., and Viard, V. B., 1990, "A Physically Based Navigation Strategy for Sonar-Guided Vehicle," *International Journal of Robotic Research*, Vol. 10, No. 2, pp. 75~87.

LABMATE User Manual, 1989, Release 5. 4F. MACOME Products Catalogue, 1999, Japan.

Park, K., Chung, H., and Lee, J. G., 1997, "Dead Reckoning Navigation for an Autonomous Mobile Robot Using a Differential Encoder and a Gyroscope," *8th International Conference on Advanced Robotics*, Monterey, CA, USA, pp. 7~9.

PIC Manual, 1999, Microchips Ltd.

Schiele, B., and Crowley, J., 1994, "A Comparison of Position Estimation Techniques Using Occupancy Grids," *Proceedings of IEEE International Conferences on Robotics and Automation*, pp. 1628~1634.